

THIS DRAWING IS UNPUBLISHED. RELEASED FOR PUBLICATION  
 © COPYRIGHT - BY TYCO ELECTRONICS CORPORATION. ALL RIGHTS RESERVED.

LOC	DIST	REVISIONS			
P	LTR	DESCRIPTION	DATE	DWN	APVD
G	86	N1	REV PER ECR 06-027279	21NOV06	JR MS

- 1 TONGUE MATERIAL THICKNESS .045±.003
- △2 BODY: COPPER PER ASTM B-152, ANNEALED  
TIN PER ASTM B-545  
INSULATION: PVC, COLOR - BLUE  
METALLIC SLEEVE: COPPER PER ASTM B-152  
METALLIC BAND: STEEL PER ASTM A109
- 3 FOR .377 MAX WIRE INSULATION DIA
- △4 PRELIMINARY - NOT FOR PRODUCTION

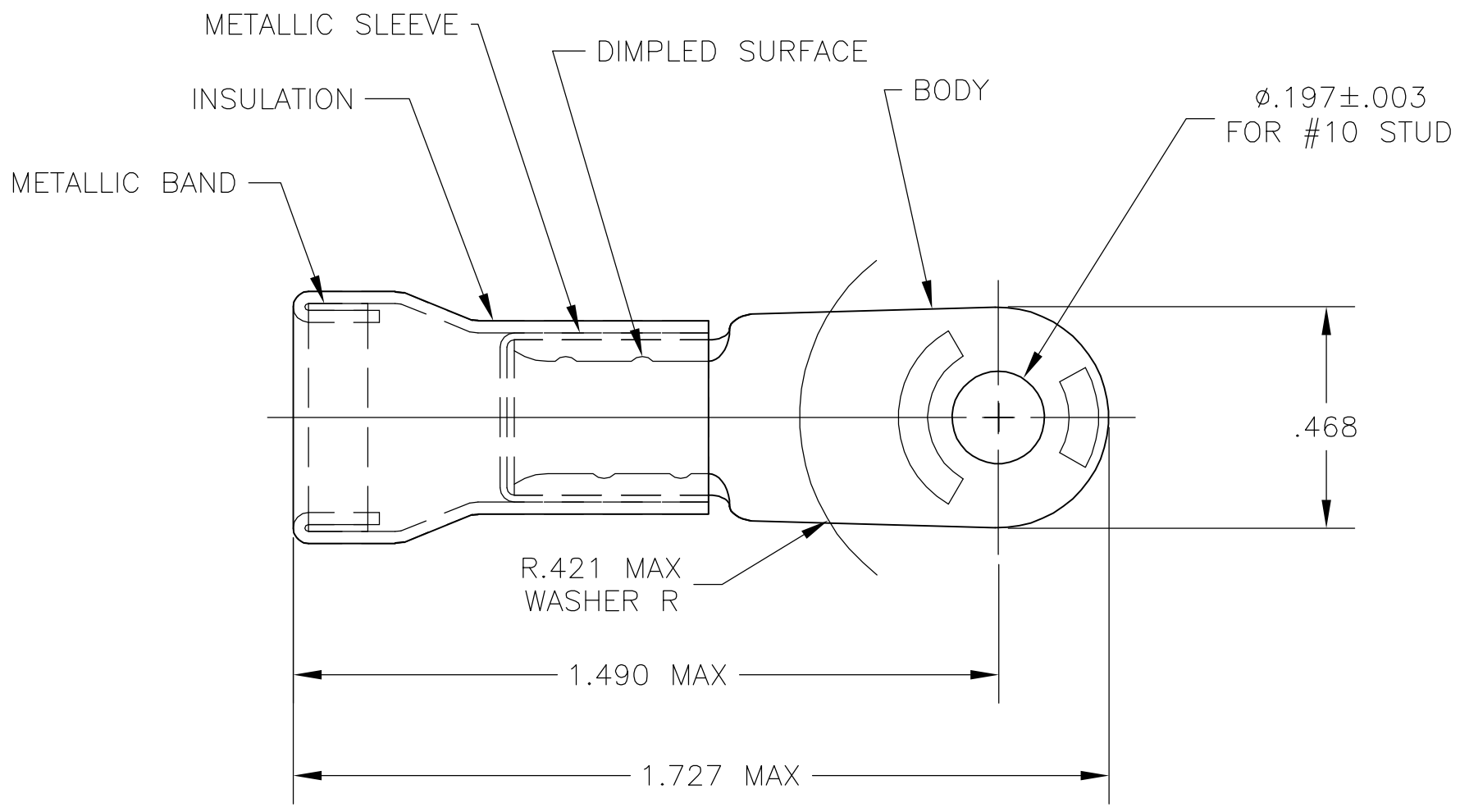

MILITARY PART NO.	QTY	PACKAGING TYPE	PART NO
---	500	TAPE & REEL	△4 322153-2
MS25036-119, CLASS 2.	100	LOOSE PIECE	322153

THIS DRAWING IS A CONTROLLED DOCUMENT.		DWN jr_ruth 02JUN04	Tyco Electronics Corporation Harrisburg, PA 17105		
DIMENSIONS: INCHES		CHK MJ SPICER 02JUN04			
TOLERANCES UNLESS OTHERWISE SPECIFIED:		APVD MJ SPICER 02JUN04	NAME TERMINAL, AMPLI-BOND, RING TONGUE WIRE SIZE: 6		
0 PLC ± - 1 PLC ± - 2 PLC ± - 3 PLC ± .008 4 PLC ± - ANGLES ± 5°		PRODUCT SPEC -	RESTRICTED TO -		
MATERIAL - △2		FINISH - △2	SIZE A3	CAGE CODE 00779	DRAWING NO C-322153
CUSTOMER DRAWING			SCALE 3:1	SHEET 1 OF 1	REV N1